

NAME:

JOB REF OR ORDER NO.:

COMPANY (if applicable):

SKIRTING PROFILE - 6"LT / 8"OG / 5"PR

TELEPHONE NO.:

COLOUR:

E-MAIL ADDRESS:

SIGNED: DATE:

Print out and mark length required and return to DiscreteHeat.

Do not scale when printing out

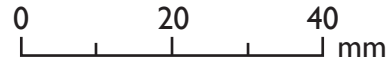

A = 140mm as standard.

B = 60mm as standard.

Leave blank if standard dimension OK.

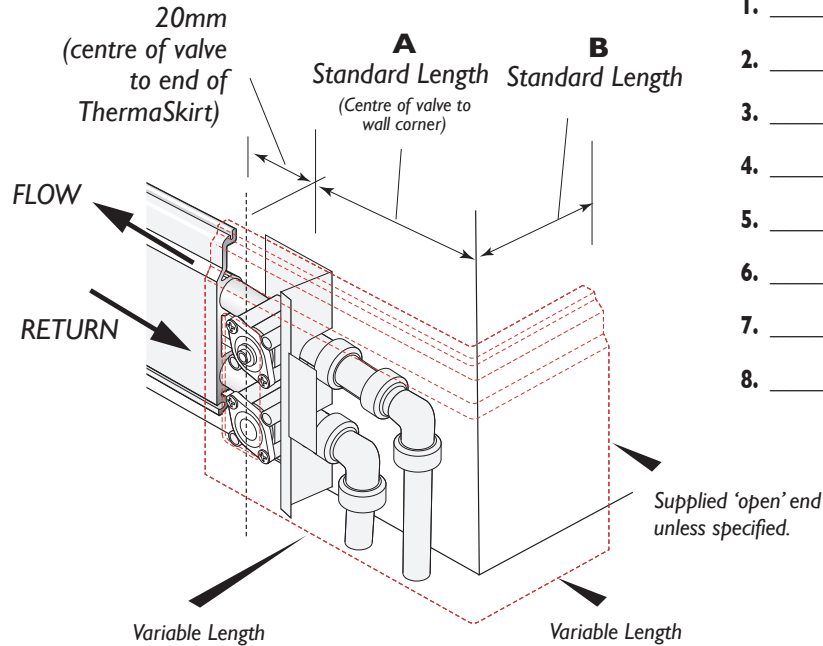

Item	Ref	DOUBLE TRV?	TRV?	Qty.	Closed?
1.	LENGTH REQUIRED: A	<input type="checkbox"/>	B	<input type="checkbox"/>	<input type="checkbox"/>
2.	LENGTH REQUIRED: A	<input type="checkbox"/>	B	<input type="checkbox"/>	<input type="checkbox"/>
3.	LENGTH REQUIRED: A	<input type="checkbox"/>	B	<input type="checkbox"/>	<input type="checkbox"/>
4.	LENGTH REQUIRED: A	<input type="checkbox"/>	B	<input type="checkbox"/>	<input type="checkbox"/>
5.	LENGTH REQUIRED: A	<input type="checkbox"/>	B	<input type="checkbox"/>	<input type="checkbox"/>
6.	LENGTH REQUIRED: A	<input type="checkbox"/>	B	<input type="checkbox"/>	<input type="checkbox"/>
7.	LENGTH REQUIRED: A	<input type="checkbox"/>	B	<input type="checkbox"/>	<input type="checkbox"/>
8.	LENGTH REQUIRED: A	<input type="checkbox"/>	B	<input type="checkbox"/>	<input type="checkbox"/>

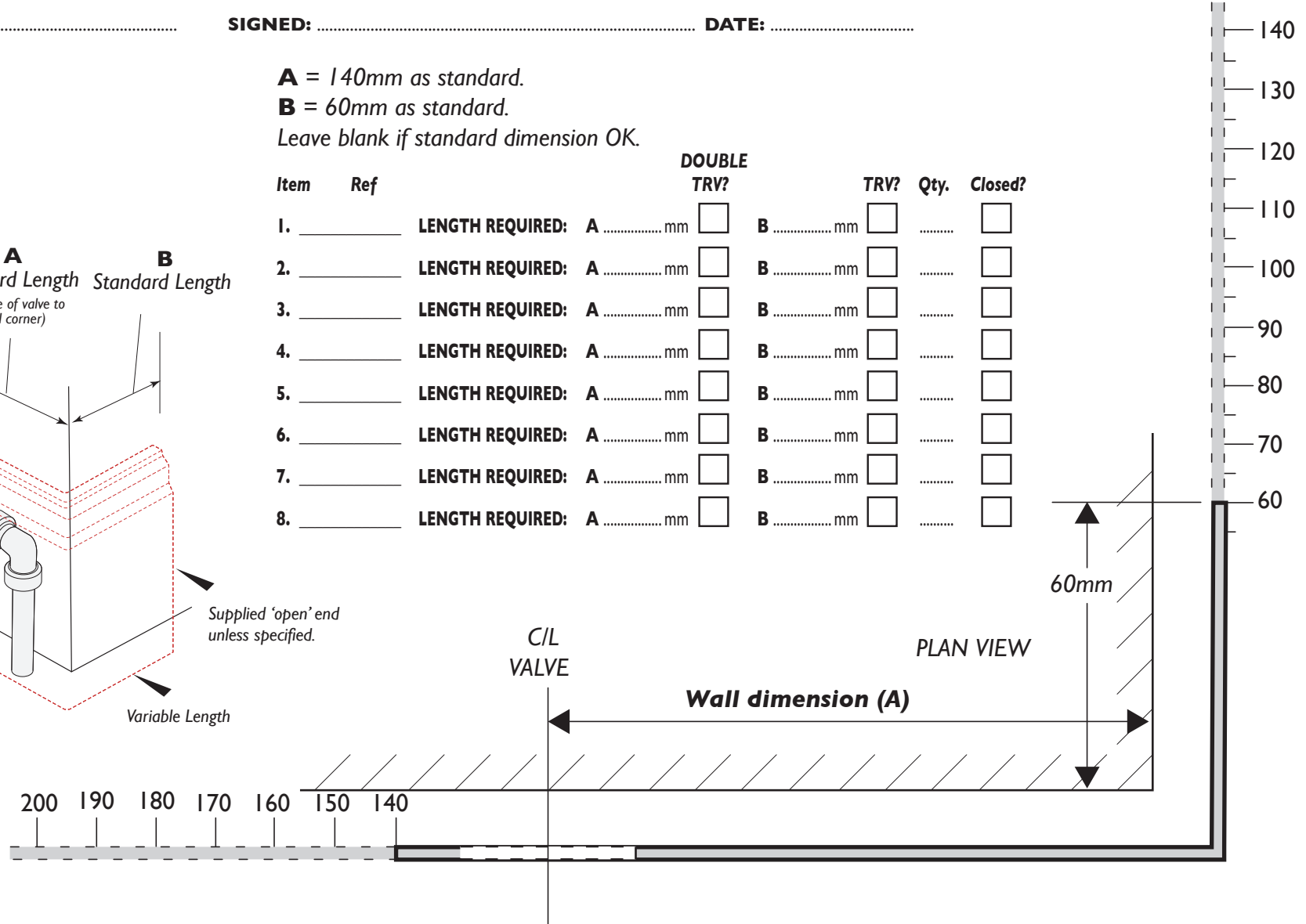

TRV EXTERNAL 90° SPECIAL COVER (Sheet 2 of 2)

RH EXTERNAL CORNER

NAME:

JOB REF OR ORDER NO.:

COMPANY (if applicable):

SKIRTING PROFILE - 6"LT / **8"OG** / **5"PR**

TELEPHONE NO.:

COLOUR:

E-MAIL ADDRESS:

SIGNED: **DATE:**

A = 140mm as standard.
B = 60mm as standard.
Leave blank if standard dimension OK.

Print out and mark length required and return to DiscreteHeat.

Do not scale when printing out

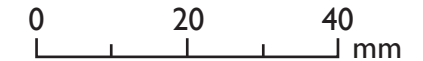

Item	Ref	TRV?	TRV?	Qty.	Closed?
1.		LENGTH REQUIRED: A mm <input type="checkbox"/>	B mm <input type="checkbox"/>	<input type="checkbox"/>
2.		LENGTH REQUIRED: A mm <input type="checkbox"/>	B mm <input type="checkbox"/>	<input type="checkbox"/>
3.		LENGTH REQUIRED: A mm <input type="checkbox"/>	B mm <input type="checkbox"/>	<input type="checkbox"/>
4.		LENGTH REQUIRED: A mm <input type="checkbox"/>	B mm <input type="checkbox"/>	<input type="checkbox"/>
5.		LENGTH REQUIRED: A mm <input type="checkbox"/>	B mm <input type="checkbox"/>	<input type="checkbox"/>
6.		LENGTH REQUIRED: A mm <input type="checkbox"/>	B mm <input type="checkbox"/>	<input type="checkbox"/>
7.		LENGTH REQUIRED: A mm <input type="checkbox"/>	B mm <input type="checkbox"/>	<input type="checkbox"/>
8.		LENGTH REQUIRED: A mm <input type="checkbox"/>	B mm <input type="checkbox"/>	<input type="checkbox"/>

