

SPECIAL ANGLE EXTERNAL CORNER/TRV (Sheet 1 of 2)

NAME:
COMPANY (if applicable):
TELEPHONE NO.:
E-MAIL ADDRESS:

JOB REF OR ORDER NO.:
SKIRTING PROFILE - 6"LT / **8"OG** / **5"PR**
COLOUR:
SIGNED: **DATE:**

DO NOT SCALE DRG WHEN PRINTING

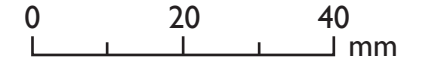

Special angle orders are 100mm unless specified here

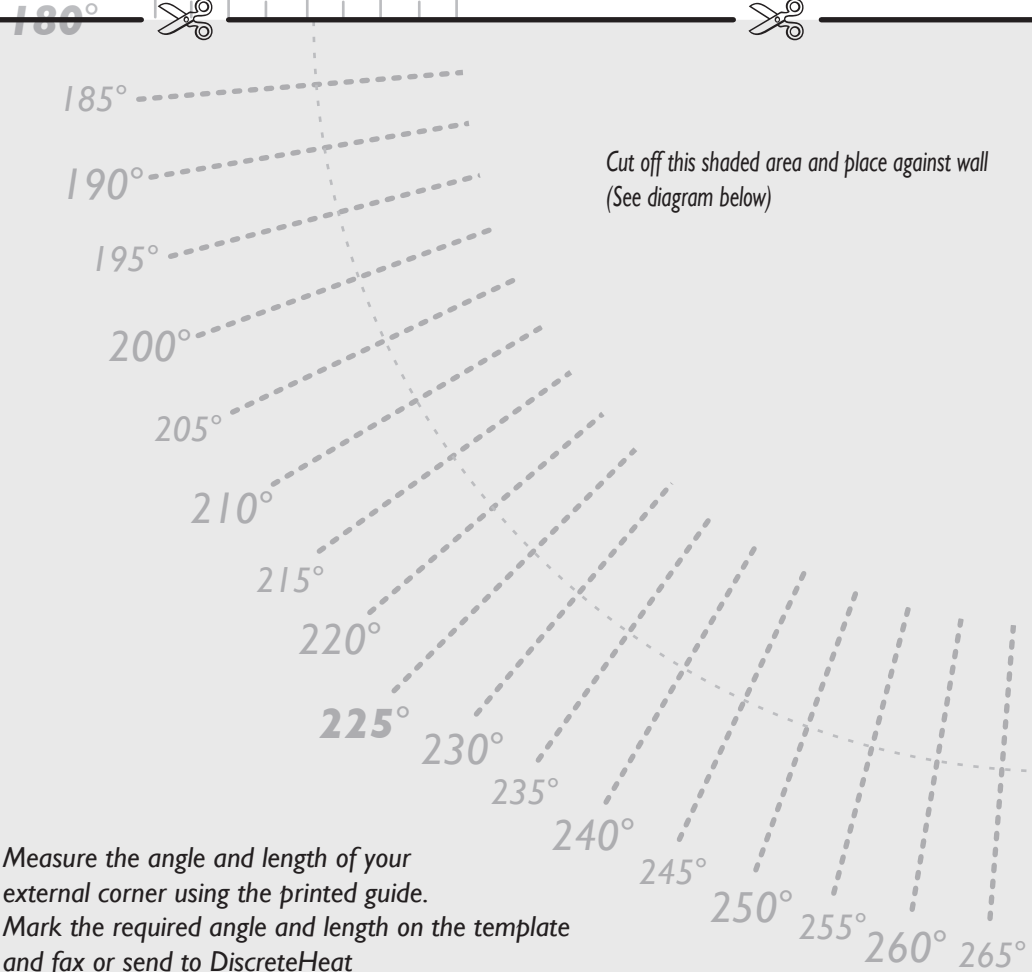
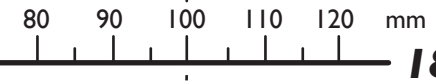

Measure the angle and length of your external corner using the printed guide. Mark the required angle and length on the template and fax or send to DiscreteHeat

ANGLE REQUIRED:
LENGTH REQUIRED: mm

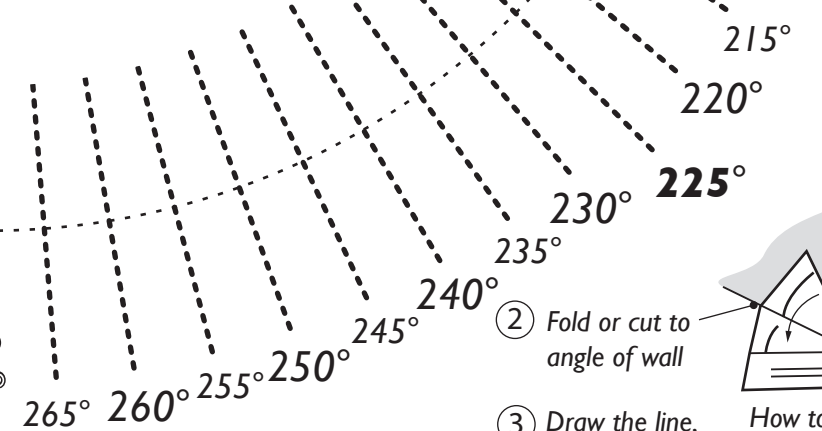

① Cut off this section of the template and place against wall

② Fold or cut to angle of wall

③ Draw the line, fill in details & fax / post

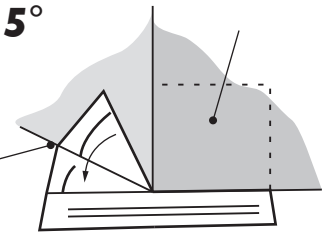

How to use the template

TRV WINDOW REQUIRED? (Sheet 2 of 2)

Add additional information here

NAME:

JOB REF OR ORDER NO.:

COMPANY (if applicable):

SKIRTING PROFILE - 6"LT / **8"OG** / **5"PR**

TELEPHONE NO.:

COLOUR:

E-MAIL ADDRESS:

SIGNED: **DATE:**

DO NOT SCALE DRG WHEN PRINTING

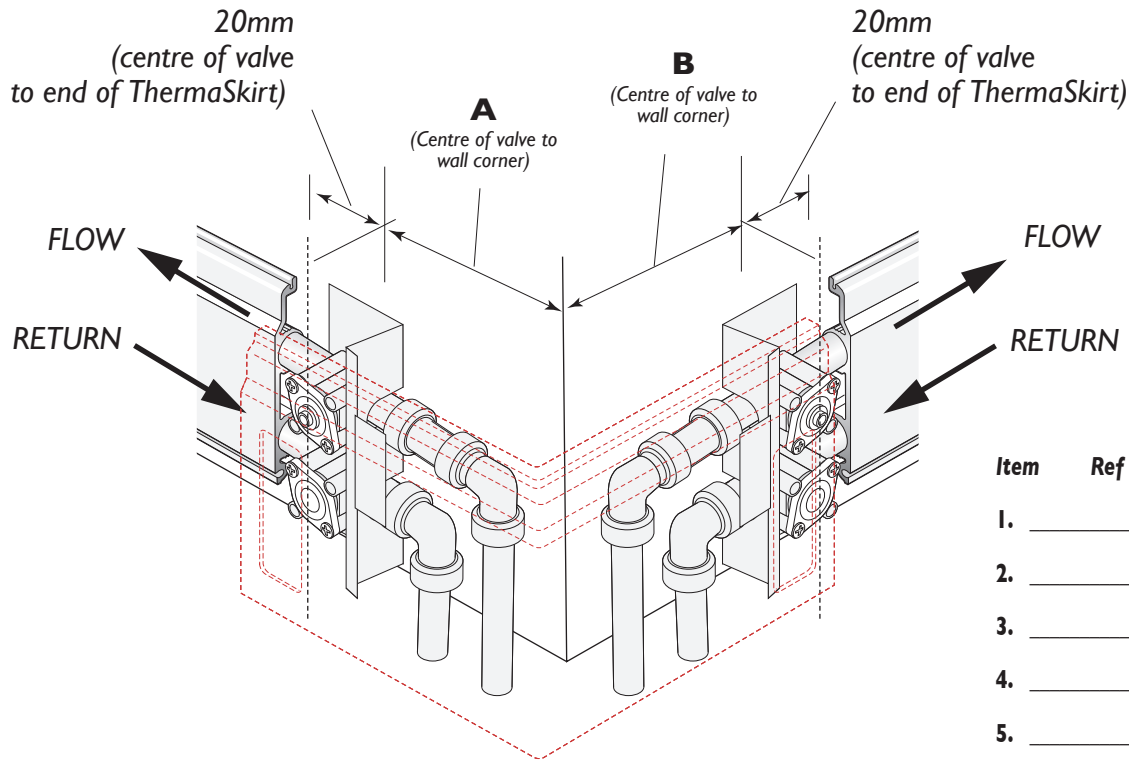
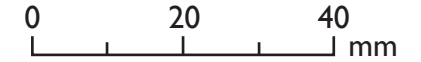

Item	Ref	LENGTH REQUIRED:	A	TRV?	B	TRV?	Qty.	Closed?
1.	_____	LENGTH REQUIRED:	A mm	<input type="checkbox"/>	B mm	<input type="checkbox"/>	<input type="checkbox"/>
2.	_____	LENGTH REQUIRED:	A mm	<input type="checkbox"/>	B mm	<input type="checkbox"/>	<input type="checkbox"/>
3.	_____	LENGTH REQUIRED:	A mm	<input type="checkbox"/>	B mm	<input type="checkbox"/>	<input type="checkbox"/>
4.	_____	LENGTH REQUIRED:	A mm	<input type="checkbox"/>	B mm	<input type="checkbox"/>	<input type="checkbox"/>
5.	_____	LENGTH REQUIRED:	A mm	<input type="checkbox"/>	B mm	<input type="checkbox"/>	<input type="checkbox"/>
6.	_____	LENGTH REQUIRED:	A mm	<input type="checkbox"/>	B mm	<input type="checkbox"/>	<input type="checkbox"/>
7.	_____	LENGTH REQUIRED:	A mm	<input type="checkbox"/>	B mm	<input type="checkbox"/>	<input type="checkbox"/>
8.	_____	LENGTH REQUIRED:	A mm	<input type="checkbox"/>	B mm	<input type="checkbox"/>	<input type="checkbox"/>